

---

# INHIBITION OF *Aspergillus flavus* GROWTH AND AFLATOXIN B1 PRODUCTION IN STORED MAIZE GRAINS EXPOSED TO VOLATILE COMPOUNDS OF *Trichoderma harzianum* RIFAI

---

Luisa Elena Mejía Agüero, Rafael Alvarado, Amaury Martínez and Blas Dorta

## SUMMARY

Inhibition of aflatoxin B1 production and *A. flavus* biomass accumulation in stored maize with volatile compounds (VCs) produced by *T. harzianum* was achieved under laboratory conditions. Gamma-irradiated (3Kgrey) maize grains inoculated with *A. flavus* were exposed to VCs produced by *T. harzianum* cultured for 15 days in Malt Extract Agar (MEA) or Defatted Corn Germ - Rice Husk (DCGRH) media. *A. flavus* biomass accumulation and aflatoxin B1 production

decreased by 31.7% and 51.87%, respectively, when *T. harzianum* was cultured in MEA. No inhibitory effect was seen in DCGRH, at the same laboratory scale conditions. However, when VCs production on DCGRH medium was scaled 24x, the proliferation of *A. flavus* was significantly inhibited (90%). These results confirm the usefulness of *T. harzianum* as a biocontrol agent for toxigenic fungi in stored grains and its possible role in mycotoxin reduction.

---

## INHIBICIÓN DEL CRECIMIENTO DE *Aspergillus flavus* Y PRODUCCIÓN DE AFLATOXINA B1 EN GRANOS DE MAÍZ ALMACENADOS BAJO LA ACCIÓN DE COMPUESTOS VOLÁTILES DE *Trichoderma harzianum* RIFAI

Luisa Elena Mejía Agüero, Rafael Alvarado, Amaury Martínez y Blas Dorta

## RESUMEN

Se demostró que el mecanismo basado en la acción de los compuestos volátiles (CVs) generados por *Trichoderma harzianum*, resultó factible en el control de crecimiento en biomasa de *Aspergillus flavus* y la producción de aflatoxina B1 en granos de maíz almacenados a escala de laboratorio. Los granos de maíz tratados con radiación gamma (3Kgrey) e inoculados posteriormente con *A. flavus*, fueron expuestos a los CVs producidos y acumulados por *T. harzianum* luego de 15 días de cultivo en los medios Agar Extracto de Malta (AEM) y Germen Desgrasado de Maíz - Cáscara de Arroz (GDMCA). Se observó una reducción de 31,7% en la biomasa

de *A. flavus* acumulada en maíz y una reducción de 51,78% en la producción de aflatoxina B1 cuando se empleó el medio AEM para el cultivo de *T. harzianum*. No se observó inhibición cuando se empleó el medio GDMCA a la misma escala de laboratorio. Sin embargo, cuando la producción de CVs a partir del medio GDMCA fue escalada en 24x, la proliferación de *A. flavus* se redujo en un 90%. Los resultados obtenidos ponen de manifiesto el potencial de *T. harzianum* como agente biocontrolador de hongos micotoxigénicos en granos almacenados, y sus posibles implicaciones en la reducción de micotoxinas.

---

## Introduction

The widespread occurrence of mycotoxins in cereal grains for human consumption and animal feed, as reflected in many reports (Mora and Lacey, 1997; Abdullah *et al.*, 1998; Dalcero *et al.*, 1998; Shöllenger *et al.*, 1999; Dutta and Das, 2001) indicates an increased proliferation of filamentous toxigenic fungi on these foodstuffs.

Maize grains are frequently contaminated by the mycotoxigenic fungi *Aspergillus flavus*, known to produce aflatoxin B1, one of the most potent carcino-

genic and cytotoxic compounds for man and some animal species (Foster *et al.*, 1983; WHO/IARC, 1993; Lewis *et al.*, 1999; Palanee *et al.*, 2000).

Corn is the cereal with the highest demand in Venezuela. In consequence, many studies have been oriented towards the description of fungal microflora and mycotoxins associated to this agricultural commodity (Martínez *et al.*, 1987; Mazzani *et al.*, 1999, 2000, 2001; Raybaudi and Martínez, 2000). These studies reveal, alarmingly, that *A. flavus* constitutes one of the principal contaminant fungi

in corn consumed in Venezuela, and aflatoxins produced by it have been found at significant levels in assayed samples.

The majority of fungal control methods for maize are based on the application of wide-spectrum chemical agents. These present, however, multiple deficiencies such as animal and human toxicity, environmental contamination, induced resistance and low effectiveness on seeds colonized by fungi in which mycotoxins have already been produced (OMS, 1992; PAHO/WHO, 1993; Calistru *et al.*, 1997b; Gisi *et al.*, 2002). This situation has neces-

sitated the implementation of alternative control strategies at the levels of production and storage, especially when dealing with fungi with low humidity requirements. Among these new strategies is biological control, based on the antagonistic action of one microorganism over another by attacking and contaminating cultures. So far, the most promising group for mycopathogen control belongs to the Genus *Trichoderma*, due to a variety of factors (Elad *et al.*, 1983; Lorito *et al.*, 1993; Calistru *et al.*, 1997a, b; Yedidia *et al.*, 1999, 2000; Howell *et al.*, 2000; Cooney *et al.*,

---

## KEYWORDS / Aflatoxin B1 / *Aspergillus flavus* / Biocontrol / *Trichoderma harzianum* / Volatile Compounds /

Received: 07/10/2007. Modified: 02/04/2008. Accepted: 02/07/2008.

**Luisa Elena Mejía Agüero.** M.Sc. in Food Science and Technology, Universidad Central de Venezuela (UCV). Graduate Student, UCV, Venezuela.

**Rafael Alvarado.** Technician, Escuela Técnica Industrial Luis

Caballero Mejías, Venezuela. Research Assistant, UCV, Venezuela.

**Amaury Martínez.** M.Sc. in Food Science and Technology, UCV, Venezuela. Professor, UCV, Venezuela.

**Blas Dorta.** Doctor in Biochemistry, Universidad Nacional de La Plata, Argentina. Professor, UCV, Venezuela. Address: Laboratorio de Procesos Fermentativos, Instituto de Biología Experimental, Facultad de Cien-

cias, UCV. Apartado 47114, Caracas 1050A, Venezuela. e-mail: bdorta@cantv.net.

# INIBIÇÃO DO CRESCIMENTO DE *Aspergillus flavus* E PRODUÇÃO DE AFLATOXINA B1 EM GRÃOS DE MILHO ARMAZENADOS NA PRESENÇA DE COMPOSTOS VOLÁTEIS DE *Trichoderma harzianum* RIFAI

Luisa Elena Mejía Agüero, Rafael Alvarado, Amaury Martínez e Blas Dorta

## RESUMO

Demonstrou-se que o mecanismo baseado na acção dos compostos voláteis (CVs) gerados por *Trichoderma harzianum*, resultou viável no controlo do crescimento da biomassa de *Aspergillus flavus* e na produção de aflatoxina B1 nos grãos de milho armazenados a escala de laboratório. Os grãos de milho tratados com radiação gamma (3Kgrey) e inoculados posteriormente com *A. flavus* foram expostos aos CVs produzidos e acumulados por *T. harzianum* logo após 15 dias de cultivo nos meios Agar Extracto de Malta (AEM) e Gérmem Desengordurado de Milho - Casca de Arroz (GDMCA). Observou-se uma redução de 31,7% na biomassa de *A. flavus* acumulada no mi-

lho, e uma redução de 51,78% na produção de aflatoxina B1 quando se aplicou ao meio AEM para o cultivo de *Trichoderma harzianum*. Não se observou inibição quando se aplicou ao meio GDMCA à mesma escala de laboratório. Por outro lado, quando a produção de CVs a partir do meio GDMCA foi a uma escala de 24x, a proliferação de *A. flavus* reduziu-se a 90%. Os resultados obtidos salientam e põem em evidência o potencial de *T. harzianum* como agente biocontrolador de fungos micotoxigenicos nos grãos armazenados, e as suas possíveis implicações na redução de micotoxinas.

2001; Okigbo and Ikediugwu, 2001; Dal Bello *et al.*, 2002; Humphris *et al.*, 2002) including a reduction in micotoxin production when the mycopathogen grows together with *Trichoderma* species (Cooney *et al.*, 2001). Among the control mechanisms associated with *Trichoderma* spp., there is an antagonistic action with volatile compounds as shown by the fungistatic effects on wood-rotting fungi (Bruce *et al.*, 1996, 2000; Calistru *et al.*, 1997a; Wheatley *et al.*, 1997; Humphris *et al.*, 2002; Wheatley, 2002) and their efficacy in controlling apple ring rot (Kexiang *et al.*, 2002). However, available information on the possible action of the volatile compounds of *Trichoderma* spp. on mycotoxigenic fungus is scarce and limited to a few studies (Calistru *et al.*, 1997a).

Given that large-scale storage systems for maize operate as packed bed columns, and can be force-ventilated, the application of volatile compounds inhibiting mycotoxigenic fungi is seen as a possible control strategy. Thus, the central objective of this paper was to determine if the action of volatile compounds produced by *Trichoderma harzianum* is effective in preventing the proliferation of *Aspergillus flavus* and the subsequent production of aflatoxin B1 in stored maize.

## Materials and Methods

### Microorganisms

*Trichoderma harzianum* (LP-FIBE-5) was originally obtained from a corn plantation in Por-

tuguesa State, Venezuela, and the micotoxigenic *Aspergillus flavus* (LPFIBE-20) was isolated from local maize seeds. Both fungal isolates were supplied by the Centro Venezolano de Colecciones de Microorganismos (CVCVM), Venezuela. Fungi were maintained in periodical subcultures in slants of Malt Extract Agar (MEA; Hi Media Laboratories, Mumbai, India) supplemented with 2.35g.l<sup>-1</sup> glycerol.

### Maize

To reduce the contaminant microbial load, commercial yellow corn was placed in covered aluminum containers (14.7×9.7×6cm) and irradiated at 3Kgrey in the Gamma Radiation Sterilization Plant at the Instituto Venezolano de Investigaciones Científicas (IVIC). Irradiated maize was kept at 4°C until used.

### Inoculum preparation

Inocula of both *A. flavus* and *T. harzianum* were prepared from sporulated cultures developed at ambient temperature during 15 days on MEA slants. Spores were collected by adding sterile 0.1% Tween 80 in distilled water and shaking by hand. Spore counts were made using a Neubauer haemocytometer.

### Volatile compounds production by *T. harzianum*

Volatile compounds (VC) production of *T. harzianum* was carried out at two different scales, employing roux bottles (small scale) and aluminum trays (large

scale), with work surfaces of 216 and 2591cm<sup>2</sup>, respectively. Roux bottles were loaded with 330ml of MEA medium or, alternatively, 154g of a solid medium formulated with defatted corn germ - rice husk (DCGRH), a modification of the BH medium described by Dorta *et al.* (1990). In the latter medium, the rice bran was substituted by defatted corn germ, a byproduct supplied by Promesa, Aragua State, Venezuela. Both media (MEA and DCGRH) were sterilized at 120°C during 20min.

In the large scale experiment, DCGRH medium (400g) was poured uniformly over the entire surface of the sterilized aluminum trays. In this case, the medium was prepared in Erlenmeyer flasks, sterilized and inoculated with *T. harzianum* spores before being transferred to the trays. Each tray was covered with a polyethylene bag (previously sterilized by gamma radiation at 2.5Mrad). The whole operation was performed in a laminar flow cabinet.

MEA cultures were started by adding 10ml of spore suspension to a concentration of 10<sup>6</sup> spores/ml, while DCGRH cultures were inoculated with 10<sup>6</sup> spores/g of solids. Incubations were done at 25±1°C for 15 days in the presence of continuous artificial light.

### Antagonism of *T. harzianum* vs *A. flavus*

Roux bottles containing *T. harzianum* grown on MEA and DCGRH media for two weeks, and their controls (media with-

out inocula), were connected to glass columns (2.5cm diameter and 30cm long) packed with 62g of maize inoculated with *Aspergillus flavus* at 10<sup>3</sup> spores/g. The roux bottle-column system remained connected allowing gaseous exchange during 15 days (Figure 1a), after which columns were dismantled to determine the accumulated fungal biomass and the aflatoxin B1 levels present.

Aluminum trays containing 15 day developed cultures of *T. harzianum*, and their respective controls, were connected through a tubing system to 4l plastic containers packed with 2kg of maize inoculated with *Aspergillus flavus* at the range of 10<sup>3</sup> spores/g (Figure 1b). Volatile compounds of *T. harzianum* were transferred to the plastic containers using aquarium peristaltic pumps which operated 1min daily, to guarantee a complete change of the void volume of the corn packed beds.

### Determination of fungal biomass content in maize

The total *A. flavus* biomass accumulated in each column was determined indirectly using measurements of N-acetylglucosamine, following the method of Ride and Drisdale (1972). Columns containing contaminated and treated maize were sterilized at 120°C during 20min and oven dried at 60°C to constant weight. Immediately afterwards, the total content of each column was powdered with an intermediate mill (Thomas Wiley, Swedesboro, NJ, USA) until a particle size of 60 mesh was obtained, and dried

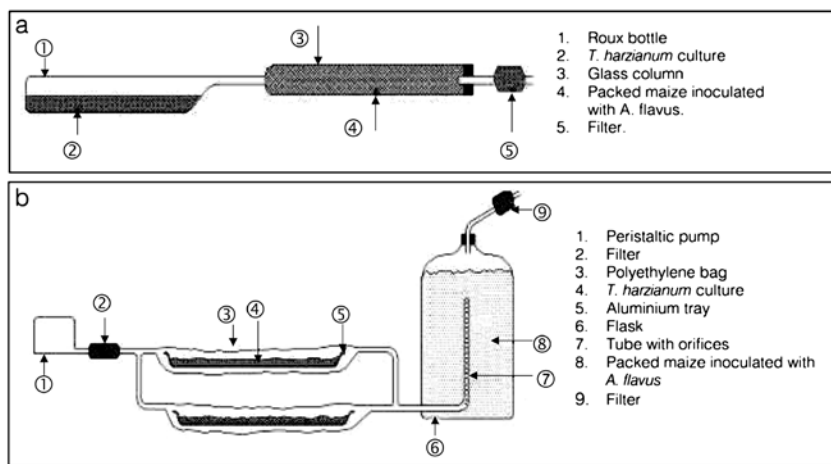

Figure 1. Schematic drawing of the systems employed to determine the antagonistic effect of VCs from *T. harzianum* against *A. flavus*. a: Roux bottles (216cm<sup>2</sup>) - glass columns system. b: Aluminium trays (2,591cm<sup>2</sup>) - plastic container system.

again at 60°C to constant weight. Subsamples of known weights 50-80mg were taken from each treatment, and processed following the protocol described by Ride and Drisdale (1972).

The expression  $x = (GP)/G_m$  was used to calculate biomass content, where x: biomass content expressed in mg/g of maize, in dry base; G: glucosamine content in the sample, in mg/g of maize;  $G_m$ : glucosamine content in the mycelium in mg/g; and P is the sample weight in g.

For the determination of  $G_m$  *A. flavus* was cultivated in MEA plates. Mycelia were harvested by centrifugation, washed twice in distilled water, and oven dried at 60°C until constant weight. A known weight sample was processed using the Ride and Drisdale (1972) protocol for N-acetylglucosamine determination.

#### Aflatoxin content determination in maize

Aflatoxin determination was performed using Aflatest immunoaffinity columns ( $P \geq 10$ ng/g; Vicam, Watertown, MA, USA). For each treatment 50g samples were taken and processed according to the procedure described by the manufacturer.

#### Statistical analysis

Variance analyses and means comparison tests were applied to the results with the statistical package 2001 Statistica for Windows (StatSoft, Inc., Tulsa, AZ, USA).

## Results and Discussion

### Effect of VCs from *T. harzianum* on *A. flavus* proliferation

The effectiveness of malt extract as a culture medium for some species of *Trichoderma*, in antagonistic processes mediated by volatile compounds, has been established in earlier studies (Wheatley *et al.*, 1997). Although in those studies reference is made to volatile compound action on a specific group of wood-rotting fungi (*Neolentinius lepideus*, *Postia placenta*, *Gloeophyllum trabeum* and *Coriolus versicolor*, among others), such action could be extended to other fungi of phytosanitary importance, such as *A. flavus*. In this study, the effect of VCs produced by *T. harzianum* in MEA was tested on the proliferation of *A. flavus* inoculated

on previously irradiated maize grains. The corresponding analysis of variance revealed significant differences ( $p < 0.05$ ) between the values of *A. flavus* biomass accumulated on irradiated maize and those of non-exposed samples (Table I).

The confirmed observation that VCs produced by *T. harzianum* were capable of considerable inhibition (31.7%) of *A. flavus* proliferation is noteworthy,

since this may be possible to implement in large-scale control processes. Malt Extract Agar would not, however, be economically feasible as a culture medium, due to its high production cost. The DCGRH medium, formulated with low-cost agroindustrial byproducts, was tested as an alternative. When MEA was substituted by DCGRH as the culture medium for the production of VCs by *T. harzianum*, the total biomass of *A. flavus* was not statistically different ( $p > 0.05$ ) between grains exposed to VCs and the control, at the same scale (Table I). This may have occurred due to changes in type or concentration of VCs because of media substitution, an effect reported for some species of *Trichoderma* (Bruce *et al.*, 1996; Wheatley *et al.*, 1997).

Also, direct observation of maize packed in columns exposed to VCs from *T. harzianum* cultured in DCGRH, suggests a

differential effect associated with their concentration. An axial gradient in the proliferation of *A. flavus* was observed, being lower in the immediate surroundings of the point of entry of the volatiles and higher at the distal end.

An experimental system for increasing the VC concentration using connected trays in parallel was designed on the basis of the area scale destined for *T. harzianum* culture (Figure 1b).

With this system, the cultured surface of *T. harzianum* increased 24x and the weight of treated maize increased 60x. The VCs produced by *T. harzianum* were transferred to the corn by pumping fermentation gases in sufficient quantities to produce a complete daily turnover of the void volume of the packed corn bed. Under these conditions, *A. flavus* proliferation was reduced by 90% after 15 days (Table I). Clearly, the antagonistic activity of the VCs reduces *A. flavus* proliferation in stored maize, and the production of VCs may also be scaled up for implementation at greater volumes. However, direct application of fermentation gases of *T. harzianum* to stored maize causes an increase in the moisture content, characteristic of solid-state fermentation systems. Thus, their use must be accompanied by the use of dehydration devices to ensure the low-humidity conditions necessary for maize storage systems.

#### Effect of VCs of *T. harzianum* on aflatoxin B1 levels

VCs produced by *T. harzianum* cultured 15 days in MEA significantly reduced ( $p < 0.05$ )

TABLE I  
BIOMASS OF *A. flavus* AND AFLATOXIN PRODUCTION IN STORED MAIZE WITH VOLATILE COMPOUNDS FROM *T. harzianum* GROWN ON MALT EXTRACT AGAR (MEA) AND DEFATTED CORN GERM RICE HUSK (DCGRH)

Assay condition	<i>A. flavus</i> biomass (mg/g of maize)		Specific aflatoxin (ng aflatoxin/mg of <i>A. flavus</i> biomass)
	A	B	
MEA without <i>T. harzianum</i> (control)	29.00 ± 8.82 b	—	24.33 ± 4.46 a
MEA with <i>T. harzianum</i>	19.80 ± 7.15 a	—	12.62 ± 3.41 b
DCGRH without <i>T. harzianum</i> (control)	23.50 ± 10.12 ab	25.50 ± 0.54 a	—
DCGRH with <i>T. harzianum</i>	18.22 ± 4.25 a	2.68 ± 1.72 b	—

A, C: Roux bottles - glass columns (small scale). B: Aluminum trays - plastic container (large scale). Values represent the mean from two independent assays ±SD. Values in the same column followed by different letters are significantly different ( $p < 0.05$ ).

levels of specific aflatoxin (ng aflatoxin/mg of *A. flavus* biomass) in inoculated maize ( $10^3$  spores/ml) as compared to non-exposed maize (Table I).

Although the inhibition of aflatoxin B1 production by volatiles generated from cotton leaves has been reported (Zeringue and McCormick, 1990; Zeringue *et al.*, 1996; Greene *et al.*, 1999), this study represents the first report of the inhibiting effect produced by the VCs of *T. harzianum* on *A. flavus* proliferation in stored maize.

*Trichoderma* spp. volatiles identified as inhibitors of wood rotting fungi (Bruce *et al.*, 1996; Wheatley *et al.*, 1997) and those identified in cotton leaves (Zeringue *et al.*, 1990; Zeringue *et al.*, 1996) have shown similarities with hexanal, octanal and 1-heptanal compounds. These findings suggest that volatile aldehydes produced by *Trichoderma* spp. should be responsible for the inhibiting effect on the micotoxigenic fungus *A. flavus*.

Further work is required to characterize the chemical nature of the volatile compounds reported in this study. It will help establish relationships with volatile agents previously identified by other authors, and raise the possibility for synthesizing such compounds and investigating its use as control agents on *A. flavus* growing in stored grains.

#### ACKNOWLEDGMENTS

The authors thank Domenico Pavone for valuable technical assistance, Ron Wheatley for kindly sending copies of his papers, FONACIT (Fondo Nacional de Investigaciones Científicas, Venezuela) for financial support through grants S1-2001000918 and G97000623, and the BID-FONACIT II Fellowship Program.

#### REFERENCES

- Abdullah N, Nawawi A, Othman I (1998) Survey of fungal counts and natural occurrence of aflatoxins in Malaysian starch-based foods. *Mycopathologia* 143: 53-58.
- Bruce A, Kundzewicz A, Wheatley R (1996) Influence of culture age on the volatile organic compounds produced by *Trichoderma aureoviride* and associated inhibitory effects on selected wood decay fungi. *Mat. Organismen* 30: 79-94.
- Bruce A, Wheatley R, Humphris S, Hackett C, Florence M (2000) Production of volatile organic compounds by *Trichoderma* in media containing different amino acids and their effects on selected wood decay fungi. *Holzforschung* 54: 481-486.
- Calistru C, McLean M, Berjak P (1997a) *In vitro* studies on the potential for biological control of *Aspergillus flavus* and *Fusarium moniliforme* by *Trichoderma* species. *Mycopathologia* 137: 115-124.
- Calistru C, McLean M, Berjak P (1997b) *In vitro* studies on the potential for biological control of *Aspergillus flavus* and *Fusarium moniliforme* by *Trichoderma* species. *Mycopathologia* 139: 115-121.
- Cooney JM, Lauren DR, di Menna ME (2001) Impact of competitive fungi on Trichothece production by *Fusarium graminearum*. *J. Agric. Food Chem.* 49: 522-526.
- Dal Bello GM, Mónaco CI, Simón MR (2002) Biological control of seedling blight of wheat caused by *Fusarium graminearum* with beneficial rhizosphere microorganisms. *World J. Microbiol. Biotechnol.* 18: 627-636.
- Dalcero A, Magnoli C, Luna M, Ancasi G, Reynoso MM, Chiachiera S, Miazza R, Palacio G (1998) Mycoflora and naturally occurring mycotoxins in poultry feeds in Argentina. *Mycopathologia* 141: 137-43.
- Dorta B, Bosch A, Arcas JA, Ertola RJ (1990) High level of sporulation of *Metarhizium anisopliae* in a medium containing byproducts. *Appl. Microbiol. Biotechnol.* 33: 712-715.
- Dutta TK, Das P (2001) Isolation of aflatoxigenic strain of *Aspergillus* and detection of aflatoxin B1 from feeds in India. *Mycopathologia* 151: 29-33.
- Elad Y, Chet I, Boyle P, Henis Y (1983) Parasitism of *Trichoderma* spp on *Rhizoctonia solani* and *Sclerotium rolfsii* - Scanning Electron Microscopy and Fluorescence Microscopy. *Phytopathology* 73: 85-88.
- Foster PL, Eisenstadt E, Miller JH (1983) Base substitution mutations induced by metabolically activated aflatoxin B1. *Proc Natl. Acad. Sci.* 80: 2695-2698.
- Gisi U, Sierotzki H, Cook A, McCaffery A (2002) Mechanisms influencing the evolution of resistance to Qo inhibitor fungicides. *Pest Manag. Sci.* 58: 859-867.
- Greene-McDowelle DM, Ingber B, Wright MS, Zeringue HJ, Bhatnagar D, Cleaveland T (1999) The effects of selected cotton-leaf volatiles on growth, development and aflatoxin production of *Aspergillus parasiticus*. *Toxicon* 37: 883-893.
- Howell CR, Hanson LE, Stipanovic RD, Puckhaber LS (2000) Induction of Terpenoid synthesis in cotton roots and control of *Rhizoctonia solani* by seed treatment with *Trichoderma virens*. *Phytopathology* 90: 248-252.
- Humphris SN, Bruce A, Buultjens E, Wheatley RE (2002) The effects of volatile microbial secondary metabolites on protein synthesis in *Serpula lacrymans*. *FEMS Microbiol. Lett.* 210: 215-219.
- Kexiang G, Xiaoguang L, Yonghong L, Tianbo Z, Shuliang W (2002) Potencial of *Trichoderma harzianum* and *T. atroviride* to control *Botryosphaeria berengeriana* f. sp. *piricola*, the cause of apple ring rot. *J. Phytopathol.* 150: 271-276.
- Lewis CW, Smith JE, Anderson JG, Freshney RI (1999) Increased cytotoxicity of food-borne mycotoxins toward human cell lines in vitro via enhanced cytochrome p450 expression using the MTT bioassay. *Mycopathologia* 148: 97-102.
- Lorito M, Harman GE, Hayes CK, Broadway RM, Tronsmo A, Woo SL, Di Pietro A (1993) Chitinolytic enzymes produced by *Trichoderma harzianum*: Antifungal Activity of purified endochitinase and chitobiosidase. *Phytopathology* 83: 302-307.
- Martínez A, Trucksess M, Park D (1987) Analysis of Venezuelan corn for aflatoxin and *Aspergillus flavus* or *Aspergillus parasiticus* contamination. In Llewellyn GC, O'Rear CE (Eds.) *Biodeterioration Research 1*. Plenum. New York, USA. pp:111-118.
- Mazzani C, Borges O, Luzón O, Barrientos V, Quijada P (1999) Incidencia de *Aspergillus flavus*, *Fusarium moniliforme*, aflatoxinas y fumonisinas en ensayos de híbridos de maíz en Venezuela. *Fitopatol. Venez.* 12: 9-13.
- Mazzani C, Borges O, Luzón O, Barrientos V, Quijada P (2000) *Fusarium moniliforme*, fumonisinas y *Aspergillus flavus* en granos de híbridos de maíz en el estado Guárico, Venezuela. *Rev. Fac. Agron (LUZ)* 17: 185-195.
- Mazzani C, Borges O, Luzón O, Barrientos V, Quijada P (2001) Occurrence of *Fusarium moniliforme* and fumonisins in kernels of Maize hybrids in Venezuela. *Braz. J. Microbiol.* 32: 345-349.
- Mora M, Lacey J (1997) Handling and aflatoxin contamination of white maize in Costa Rica. *Mycopathologia* 138: 77-89.
- Okigbo RN, Ikediugwu FEO (2001) Biological control of tuber surface mycoflora of yams (*Dioscorea rotundata*) *Trop Sci.* 41: 85-89.
- OMS (1992) *Consecuencias sanitarias del empleo de plaguicidas en la agricultura*. Organización Mundial de la Salud. Geneve, Switzerland. 128 pp.
- PAHO/WHO (1993) *Pesticides and health in the Americas*. Division of Health and Environment. Environmental, Series N°12. Washington, DC, USA. 109 pp.
- Palanee T, Dutton MF, Chuturgoon A (2000) Cytotoxicity of aflatoxin B1 and its chemically synthesized epoxide derivative on the A459 human epithelioid lung cell line. *Mycopathologia* 151: 155-159.
- Raybaudi R, Martínez A (2000) Incidencia e identificación de la micobiota en granos de maíz (*Zea mays* L) y comparación de medios de cultivo para la determinación de mohos toxigénicos. *Fitopatol. Venez.* 13: 15-18.
- Ride JP, Drisdale RB (1972) A rapid method for the chemical estimation of filamentous fungi in plant tissue. *Physiol. Plant Pathol.* 2: 7-15.
- Shöllenberger M, Suchy S, Terry H, Drochner W, Martin H (1999) A survey of *Fusarium* toxins in cereal-based foods marketed in an area of southwest Germany. *Mycopathologia* 147: 49-57.
- Wheatley RE (2002) The consequences of volatile organic compound mediated bacterial and fungal interactions. *Ant. Leeuw.* 81: 357-364.
- Wheatley R, Hackett C, Bruce A, Kundzewicz A (1997) Effect of substrate composition on production of volatile organic compounds from *Trichoderma* spp. Inhibitory to wood decay fungi. *Int. Biodeter. Biodegrad.* 39: 199-205.
- WHO/IARC (1993) *Monographs on the evaluation of carcinogenic risk to humans*. Vol 56. International Agency for Research on Cancer (IARC). Lyon, France. 245 pp.
- Yedidia I, Benhamou N, Chet I (1999) Induction of defense responses in cucumber plants (*Cucumis sativus* L.) by the biocontrol agent *Trichoderma harzianum*. *Appl. Env. Microbiol.* 65: 1061-1070.
- Yedidia I, Benhamou N, Kapulnik Y, Chet I (2000) Induction and accumulation of PR protein activity during early stages of root colonization by the mycoparasite *Trichoderma harzianum* strain T-203. *Plant Physiol. Biochem.* 38: 863-873.
- Zeringue HJ, McCormick SP (1990) Aflatoxin production in cultures of *Aspergillus flavus* incubated in atmospheres containing selected cotton leaf-derived volatiles. *Toxicon* 28: 445-448.
- Zeringue HJ, Brown RL, Neucere JN, Cleaveland TE (1996) Relationships between C<sub>6</sub>-C<sub>12</sub> alkanal and alkenal volatile contents and resistance of maize genotypes to *Aspergillus flavus* and aflatoxins production. *J. Agric. Food Chem.* 44: 403-407.